



Model 40-158, code 121

SPECIFICATIONS

TYPE OF CIRCUIT: Model 40-158 is a six (6) tube alternating current (A. C.) operated super-heterodyne radio having two tuning ranges covering standard and police broadcast frequencies. In addition other features of design are: Philco Loktal tubes; special high gain untuned R. F. stage; automatic volume control and a Pentode audio output stage.

TUNING RANGES: 540 to 1600 K. C.; 1.6 to 3.4 M. C.

INTERMEDIATE FREQUENCY: 455 K. C.

POWER SUPPLY: 115 volts A. C., 60 cycle.

POWER CONSUMPTION: 45 watts.

AUDIO OUTPUT POWER: 2 watts.

PHILCO TUBES USED: 7B7, R. F. Amplifier; 7A8, Converter; 7B7, I. F. Amplifier; 7C6, Detector, A. V. C., 1st Audio; 41, Power Output; 84, Rectifier.

CABINET DIMENSIONS:

Height, 38 $\frac{3}{8}$ ". Width, 28 $\frac{1}{4}$ ". Depth, 10 $\frac{1}{2}$ ".

AERIAL AND GROUND: This radio is designed to operate efficiently from a Philco Utility Aerial, Part No. 40-6384, or Safety Aerial, Part 40-6370, or a short piece of wire (20 feet). The ground of the set should be connected to a cold water pipe or any other good ground source.

ALIGNING COMPENSATING CONDENSERS

EQUIPMENT REQUIRED

Signal Generator: In order to properly adjust the various R. F. and I. F. padders of this model, a calibrated signal generator such as Philco Model 077 is required.

Aligning Indicating Device: A Vacuum Tube Voltmeter or Audio Output Meter should be used. Philco Models 027 and

028 contain both of these type meters. Procedures for connecting either of these meters are listed below.

Aligning Tools: Fibre handle screw driver, Philco Part No. 45-2610. When using the vacuum tube voltmeter to align the set, an aligning adaptor, Part No. 45-2767, is required.

CONNECTING ALIGNING METERS

Audio Output Meter: Philco Model 027 or 028 Audio Output Meter is connected to the voice coil terminals of the speaker or the plate and screen of the 41 tube and adjusted for the 0 to 10 volt A. C. scale.

Vacuum Tube Voltmeter: To use the Vacuum Tube Voltmeter as an alignment indicator make the following connections:

(1) **Adjusting I. F. Circuit:** Remove the 7B7 R. F. tube from its socket and insert the aligning adaptor, then replace the tube in the adaptor. Connect the negative terminal of the vacuum tube voltmeter to the light colored wire which protrudes from the side of the adaptor. Attach the positive terminal of the vacuum tube voltmeter to the black wire of the adaptor.

(2) **Adjusting R. F. Circuit:** To adjust the R. F. circuit, the aligning adaptor is inserted in the 7C6 second detector tube socket. The vacuum tube voltmeter remains connected to the adaptor as given in the paragraph above. With the voltmeter connected in this manner a very sensitive indication of the A. V. C. voltage is obtained when the padders are adjusted.

After connecting the aligning adaptors, adjust the compensators as shown in the tabulation below. Locations of the compensators are shown in the schematic diagram. If the output meter pointer goes off scale when adjusting the compensators, reduce the strength of the signal from the generator.

Operations in Order	SIGNAL GENERATOR		RECEIVER			SPECIAL INSTRUCTIONS
	Output Connections to Receiver	Dial Setting	Dial Setting	Control Setting	Adjust Compensators in Order	
1	Antenna Terminal	455 K. C.	580 K. C.	Vol. Cont. Max. Range Switch "Brdcst"	18A, 18B 14A, 14B	Note A
2	Antenna Terminal	1500 K. C.	1500 K. C.	Vol. Cont. Max. Range Switch "Brdcst"	13B, 13A Note B	

NOTE A — DIAL CALIBRATION: In order to adjust the receiver correctly, the dial must be aligned to track properly with the tuning condenser. To do this, proceed as follows: Turn the tuning condenser to the maximum capacity position (plates fully meshed). With the condenser in this position, set the tuning pointer on the extreme left index line at the low frequency end of the broadcast scale.

NOTE B — The oscillator padder (13B) and antenna padder (13A) are located on top of the tuning condenser (13B) at the rear and (13A) at the front of the tuning condenser.

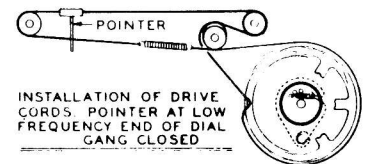
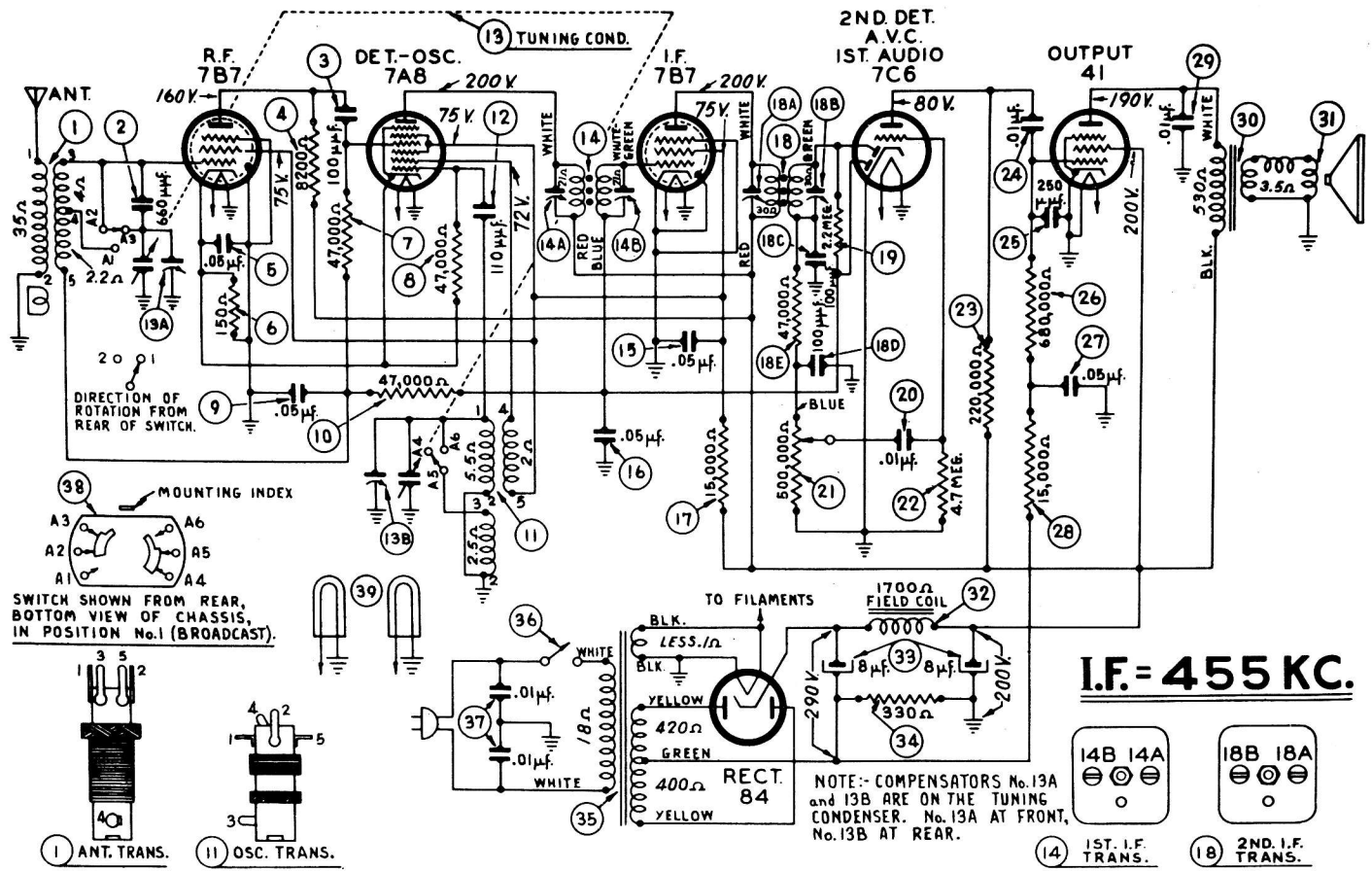

FIG. 1.



SCHMATIC DIAGRAM MODEL 40-158

Replacement Parts — Model 40-158

SCH. No.	DESCRIPTION	PART No.	SCH. No.	DESCRIPTION	PART No.	SCH. No.	DESCRIPTION	PART No.
1	Antenna Transformer	32-3303	MISCELLANEOUS PARTS			38	Pilot Lamp Socket Assembly	38-9904
2	Mica Condenser (660 mfd.)	30-1136				39	Pointer	56-1479
3	Mica Condenser (100 mfd.)	30-1128	40	Cabinet	10398C	41	Rubber Insulator (Drive Shaft)	27-9432
4	Resistor (8200 ohms, 1/2 watt)	33-282339	41	Cable and Plug (Power Supply)	L-3199	42	Socket (5 prong, type 84 tube)	27-6035
5	Tubular Condenser (.05 mfd.)	30-4519	42	Clip (Coil Mounting)	28-5002	43	Socket (6 prong, type 41 tube)	27-6036
6	Resistor (150 ohms, 1/2 watt)	33-115339	43	Dial	27-5551	44	Socket (Loktal)	27-6131
7	Resistor (47,000 ohms, 1/2 watt)	33-347339	44	Drive Cord Assembly (Tuning Condenser)	31-2400	45	Spring (Drive Cord, Tuning)	27-8751
8	Resistor (47,000 ohms, 1/2 watt)	33-347339	45	(Pointer Operation)	31-2382	46	Spring (Drive Cord, Pointer)	27-8953
9	Tubular Condenser (.05 mfd.)	30-4519	46	Insulating Bushing (Dr. Shaft)	27-9437	47	Spring (Dr. Shaft, Grounding)	27-8955
10	Resistor (47,000 ohms, 1/2 watt)	33-347339	47	Knobs (A. C. Switch, Volume, Tuning and Wave Switch)	27-4332	48	Tuning Drive Drum Assembly	38-9883
11	Oscillator Transformer	32-3255				49	Tuning Shaft	56-6052
12	Mica Condenser (110 mfd.)	30-1130				50	Washer ("C" type, tun. shaft)	28-2043
13	Tuning Condenser Assembly	31-2418						
14	1st I. F. Transformer Assy.	32-3361						
15	Tubular Condenser (.05 mfd.)	30-4519						
16	Tubular Condenser (.05 mfd.)	30-4519						
17	Resistor (15,000 ohms, 1 watt)	33-315439						
18	2nd I. F. Transformer Assembly	32-3211						
19	Resistor (2.2 meg., 1/2 watt)	33-522339						
20	Tubular Condenser (.01 mfd.)	30-4572						
21	Volume Control (500,000 ohms)	33-5319						
22	Resistor (4.7 meg., 1/2 watt)	33-547339						
23	Resist. (220,000 ohms, 1/2 watt)	33-422339						
24	Tubular Condenser (.01 mfd.)	30-4572						
25	Mica Condenser (250 mfd.)	61-0033						
26	Resist. (680,000 ohms, 1/2 watt)	33-468339						
27	Tubular Condenser (.05 mfd.)	30-4519						
28	Resist. (15,000 ohms, 1/2 watt)	33-315339						
29	Tubular Condenser (.01 mfd.)	30-4501						
30	Output Transformer	32-8056						
31	Cone and Voice Coil Assembly (Speaker Part No. 36-1480-3)	36-4086						
32	Field Coil (Replace Speaker Part No. 36-1480)	30-2447						
33	Elec. Cond. (8-8 mfd., 450 V.)	33-133439						
34	Resistor (330 ohms, 1 watt)	33-133439						
35	Power Transformer (115-130 V., 50-60 cycles)	32-8055						
	(115-130 V., 25 cycle)	32-8076						
36	A. C. Switch	42-1545						
37	Bakelite Cond. (.01-.01 mfd.)	3903-DG						
38	Wave Switch	42-1494						
39	Pilot Lamps	34-2064						

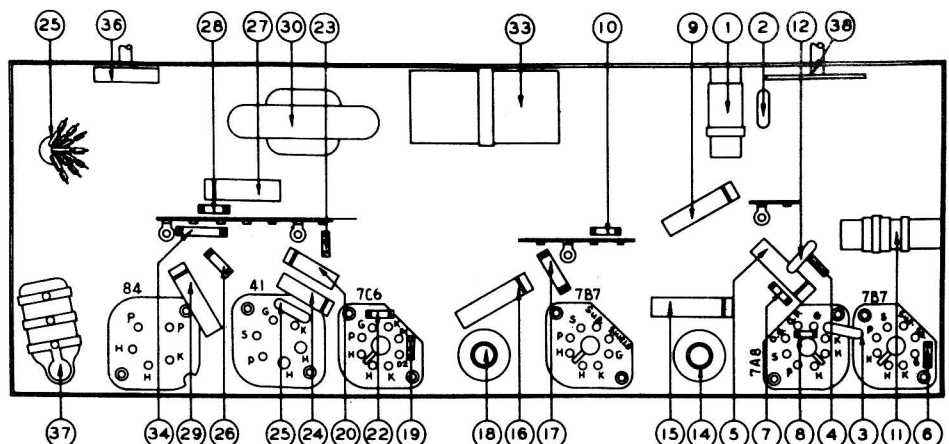

FIG. 2. PART LOCATIONS, UNDERSIDE OF CHASSIS.